

Released Assessment Questions, 2015

ANSWERS

Grade 9 Assessment of Mathematics • Academic

DIRECTIONS

Answering Multiple-Choice Questions

Answer all multiple-choice questions. If you fill in more than one answer to a question, or leave a question blank, the question will be scored zero. Incorrect answers will also be scored zero.

Answering Open-Response Questions

Do all of your work for each question in the space provided for the question **only**.

Write your solutions, including all calculations, clearly and completely.

ATTENTION:

There are more open-response questions in this booklet than a regular booklet.

**Record ALL
your answers to
multiple-choice and
open-response questions
in this booklet.**

Education Quality and
Accountability Office



You are now ready to start.



Please read the questions in the *Question Booklet*; then fill in your answers below.

To indicate your answer, use a pencil to fill in the appropriate circle below completely.

Like this: ●

Not like this: ⊗ ✓ ◐ ○

Cleanly erase your answer if you wish to change it and fill in the circle for your new answer.

Fill in only **one** circle for each question.

1 (a) (b) (c) (d)

2 (a) (b) (c) (d)

3 (a) (b) (c) (d)

4 (a) (b) (c) (d)

5 (a) (b) (c) (d)

6 (a) (b) (c) (d)

7 (a) (b) (c) (d)

8 (a) (b) (c) (d)

9 (a) (b) (c) (d)

10 (a) (b) (c) (d)

11 (a) (b) (c) (d)

12 More Snacks, Please!

Raisins and sunflower seeds are sold together in packages of 250 g. The ratio of the mass of raisins to the mass of sunflower seeds is 3 to 5.

Determine the mass of raisins in a package.

Show your work.

Raisins Sunflower

3 : 5

↓ : ↓

3x : 5x

$$3x + 5x = 250$$

$$\frac{8x}{8} = \frac{250}{8}$$

$$x = 31.25 \text{ g}$$

$$\therefore \text{ Raisins } 31.25(3) = 93.75 \text{ g.}$$

$$\text{Sunflower seeds } 31.25(5) = 156.25 \text{ g.}$$

Check

$$\frac{\text{Raisins}}{\text{Sunflower}} = \frac{3}{5} = 0.6 \quad \checkmark$$

$$= \frac{93.75}{156.25} = 0.6 \quad \checkmark$$

13 Getting Fit

Maddie enrolls in a fitness program. Her total cost is made up of a sign-up fee and a cost per class. The table below shows information about her total cost, C , in dollars, when she attends n classes.

Number of classes, n		Total cost, C (\$)
A	12	67
B	14	74

What is the sign-up fee?

Sign-up fee: \$25

Show your work.

$$\begin{array}{l}
 A(12, 67) \quad B(14, 74) \\
 m = \frac{74 - 67}{14 - 12} = \frac{7}{2} = 3.5 \\
 y = mx + b \\
 67 = 3.5(12) + b \\
 67 = 42 + b \\
 67 - 42 = b \\
 \boxed{b = 25}
 \end{array}$$

\therefore Sign up fee is \$25

Is the relationship between the number of classes Maddie attends and her total cost a partial variation or direct variation?

Circle one:

Partial variation

Direct variation

Justify your answer.

The linear relation can be modelled with the following equation

$$y = 3.5x + 25$$

Since there is a b value that is different than 0, it is a partial variation. The graph starts from a y intercept.

14 Kenny's Big Adventure

The following graph represents the relationship between Kenny's distance from home on a bike ride and time.

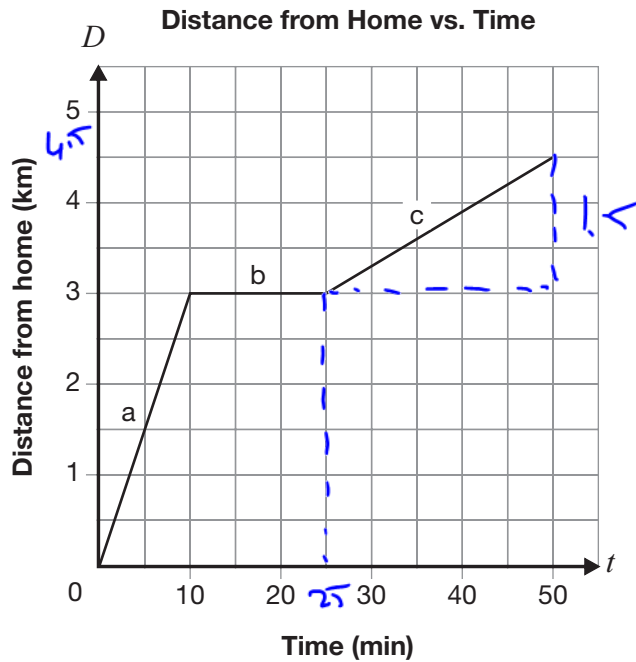

Describe the 3 segments of Kenny's ride. Include information about distance travelled, time, direction and speed, in km/min, for each segment.

Segment	Distance travelled	Time	Direction	Speed (km/min)
a	3km	10min	Away from home.	$\frac{3}{10} = 0.3 \text{ km/min}$
b	0km	15min	Taking a break	0km/min
c	1.5km	25min	Away from home	$\frac{1.5}{25} = 0.06 \text{ km/min}$

15 Comparing Relationships

Information about three linear relationships is given below.

Relationship 1

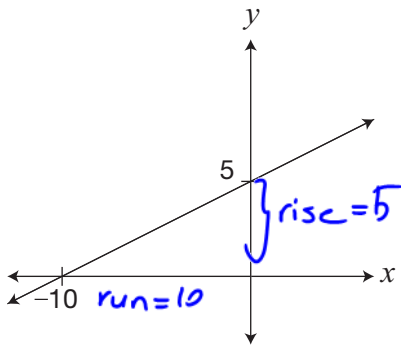

$$\text{Slope} = \frac{\text{rise}}{\text{run}} = \frac{5}{10} = 0.5$$

↓
rate of change

Relationship 2

$$3x + 6y + 1 = 0$$

$$\frac{6y}{6} = \frac{-3x - 1}{6}$$

$$y = -0.5x - \frac{1}{6}$$

$$\text{Slope} = -0.5$$

slope

Relationship 3

	x	y
A	-2	-3
B	0	-2
	2	-1
	4	0

$$A(-2, -3) \quad B(0, -2)$$

$$\text{Slope} = \frac{-2 - (-3)}{0 - (-2)} = \frac{-2 + 3}{0 + 2}$$

$$= \frac{1}{2}$$

$$= 0.5$$

Circle the relationships that have the same rate of change.

Justify your answer. Include information about all three relationships.

∴ Relationship 1 and 3 have the same rate of change (slope)

16 Making Equations!

Determine the equation of the line that has the same y-intercept as $2x + y + 6 = 0$ and is perpendicular to the line shown on the grid.

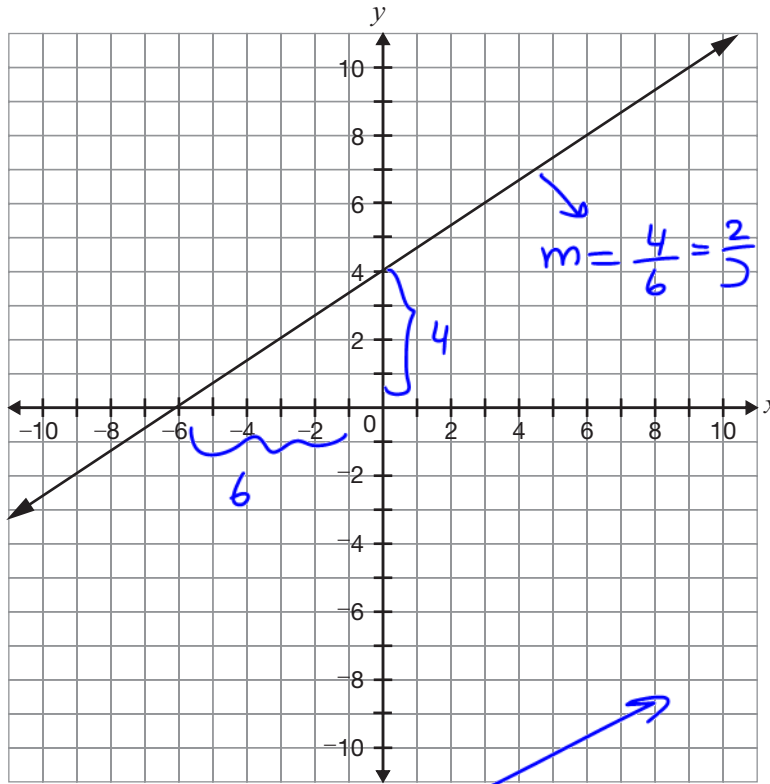

Show your work.

$$y = -2x - 6$$

y-int

y-int is a point with the coordinates $(0, -6)$ and the slope of the perpendicular line is the negative reciprocal of the line given on the left which is $-\frac{3}{2}$

A point and slope

$$(0, -6) \quad m = -\frac{3}{2}$$

$$y = mx + b$$

$$-6 = -\frac{3}{2}(0) + b$$

$$\boxed{-6 = b}$$

$$\boxed{\therefore y = -\frac{3}{2}x - 6}$$

17 Skate On!

A diagram of a community ice rink is shown below.

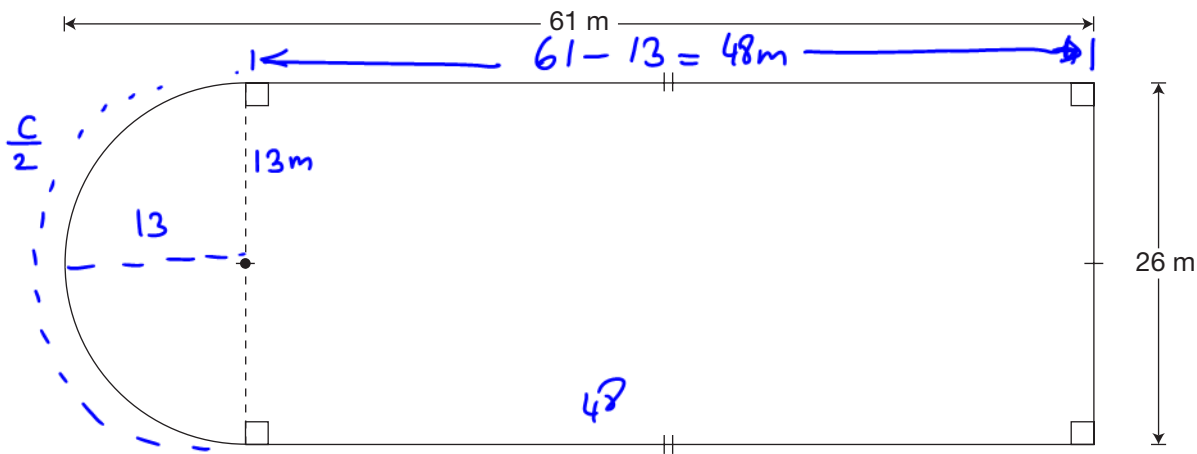

The rink is being enclosed with fencing that costs \$6.20/m.

Determine the total cost of fencing for the rink.

Show your work.

$$\begin{aligned}
 P_{\text{Total}} &= \frac{\text{Circumference}}{2} + 48 + 26 + 48 \\
 &= \frac{2\pi(13)}{2} + 122 \\
 &\approx 163 \text{ m}
 \end{aligned}$$

$$\begin{aligned}
 \text{Total Cost} &= 163 \times 6.20 \\
 &= \$1010.6
 \end{aligned}$$

\therefore It'll cost \$1010.6 to fence the rink.

18 A Schoolyard

A schoolyard is in the shape of a regular decagon, as pictured below.

$$y = \frac{(10-2)180}{10}$$

$$= 144$$

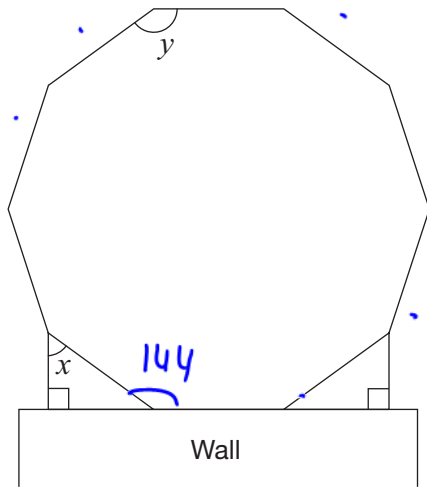

Complete the chart below with the values of x and y . Justify your answers using geometric properties.

Value	Justification using geometric properties
$x = \underline{54^\circ}$	$x + 90 = 144$ Exterior Angle Theorem $x + 90 - 90 = 144 - 90$ $x = 54^\circ$
$y = \underline{144}$	$Sum = (n-2)180$ $= (10-2)180$ $= 1440$ $y = \frac{Sum}{10} = \frac{1440}{10} = 144^\circ$ $y = 144^\circ$



Please read the questions in the *Question Booklet*; then fill in your answers below.

To indicate your answer, use a pencil to fill in the appropriate circle below completely.

Like this: ●

Not like this: ⊗ ✓ ◐ ○

Cleanly erase your answer if you wish to change it and fill in the circle for your new answer.

Fill in only **one** circle for each question.

19 a b c d

20 a b c d

21 a b c d

22 a b c d

23 a b c d

24 a b c d

25 a b c d

26 a b c d

27 a b c d

28 a b c d

29 a b c d

30 a b c d

31 a b c d

Released Assessment Questions, 2015

QUESTIONS

Grade 9 Assessment of Mathematics • Academic

Read the instructions below.

Along with this booklet, make sure you have the *Answer Booklet* and the Formula Sheet.

You may use any space in this book for rough work for multiple-choice questions only.

The diagrams in these booklets are **not** all drawn to scale.

ATTENTION:

Unlike in the actual assessment booklet, the questions in this booklet are sorted by strand.

There are more multiple-choice questions in this booklet than in a regular booklet.

Continue to read the directions on the cover of the *Answer Booklet*.

Education Quality and
Accountability Office





Remember to write your answers in your *Answer Booklet*.

1 A rectangle is divided into 5 equal sections as pictured below.

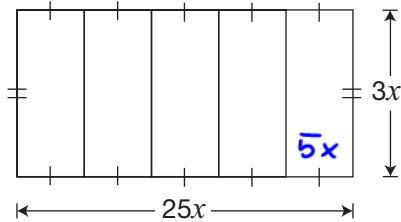

Which of the following represents the area of **one** section?

$$A = (5x)(3x) = 15x^2$$

- a $8x$
- b $8x^2$
- c $15x$
- d $15x^2$

2 The table below contains five expressions.

$p \times p \times p \times p \times p \times p$	$\rightarrow p^{1+1+1+1+1+1}$	$= p^6$
$p^2 \times p^2 \times p^2$	$\rightarrow p^{2+2+2}$	$= p^6$
$p^2 \times p^3$	$\rightarrow p^{2+3}$	$= p^5$
p^5		$= p$
p^6		$= p^6$

How many of these expressions are equivalent to $(p^2)^3$? $= p^{2 \cdot 3} = p^6$

- a 1
- b 2
- c 3
- d 4

3 A rectangle is shown below with algebraic expressions for its length and width in centimetres.

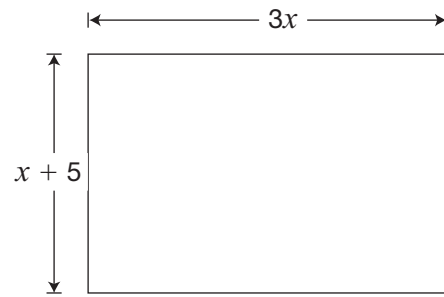

Which expression represents the area of the rectangle in cm^2 ?

$$A = L \cdot W = 3x(x+5) = 3x^2 + 15x$$

- a $4x + 5$
- b $8x + 10$
- c $3x^2 + 5$
- d $3x^2 + 15x$

4 What is the solution to the equation below?

$$\frac{2}{3}x - 4 = 20$$

a $x = 12$

b $x = 16$

c $x = 24$

d $x = 36$

$$\frac{2x}{3} = 24$$

$$\frac{2x}{2} = \frac{72}{2}$$

$$x = 36$$

5 Mia sells T-shirts from a booth at a market. She pays \$30 to rent the booth. Each T-shirt costs her \$1.50, and she sells them for \$7.50 each.

Her goal is to make \$200 after she pays for the booth and the T-shirts.

What is the minimum number of T-shirts Mia must sell to reach her goal?

a 27

b 29

c 34

d 39

let "n" be number t-shirts we sold, "c" be total cost, "s" sales

$$C = 1.5n + 30$$

$$S = 7.5n$$

$$\text{Revenue} = \text{Sales} - \text{Cost}$$

$$200 = 7.5n - (1.5n + 30)$$

$$200 = 7.5n - 1.5n - 30$$

$$200 + 30 = 6n$$

$$\frac{230}{6} = \frac{6n}{6}$$

$$n = 38.3$$

$$n \approx 39$$

6 Joanne drives for 2.5 hours at a constant speed and travels 250 km.

François drives at a constant speed exactly 10 km/h less than Joanne's speed.

Which point on the graph below could represent the distance travelled and time spent travelling for François?

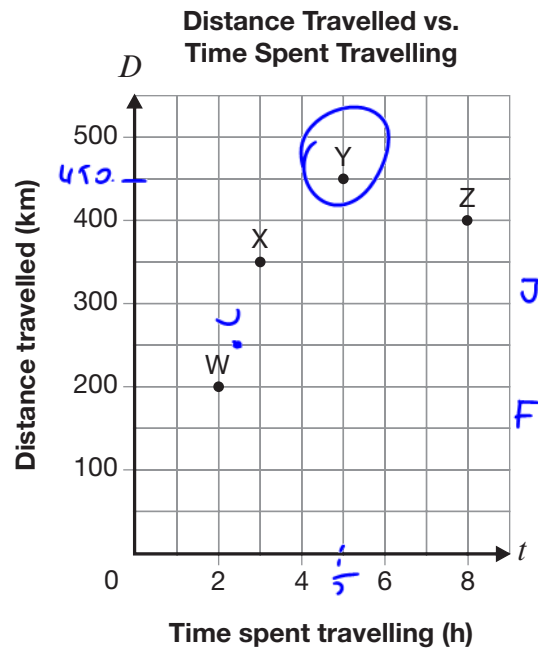

- a Z
- b Y
- c X
- d W

$$Y = \frac{450}{5} = 90 \text{ km/h}$$

7 Which of the following shows information from a linear relation between C and n ?

a

n	C
0	0
1	1
2	3

b

n	C
0	-7
2	-5
4	-3

1st dif. +2
+2

c

n	C
0	-9
4	-6
16	-3

x

d

n	C
0	2
5	4
20	6

x

8 The total cost of yearbooks for a school is made up of a \$375 set-up fee and \$25 for each yearbook purchased.

There is a linear relationship between the total cost and the number of yearbooks purchased.

What type of variation is this relationship, and what is its initial value?

- a direct variation, \$375
- b direct variation, \$25
- c** partial variation, \$375
- d partial variation, \$25

$$C = 25n + 375$$

- 9 A company ships CDs in crates of equal size. The graph below shows the relationship between the total mass of a crate and the number of CDs it contains.

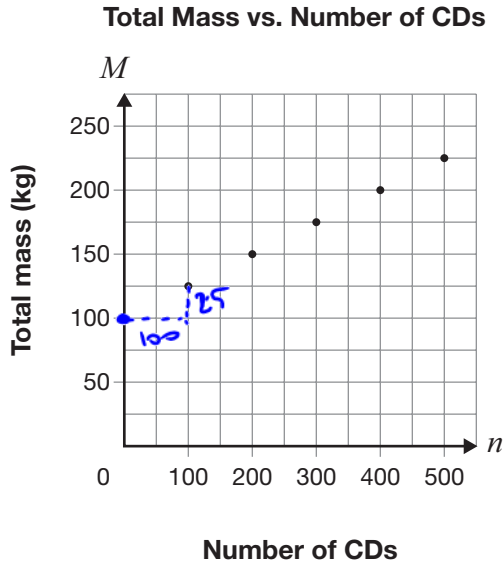

Which of the following equations represents the relationship between the total mass of a crate, M , and the number of CDs it contains, n ?

- a $M = 0.25n + 100$
- b $M = 4n + 100$
- c $M = 0.25n + 125$
- d $M = 4n + 125$

$m = \frac{25}{100} = 0.25$
 $b = 100$
 $M = 0.25n + 100$

- 10 A relationship is represented by the following graph.

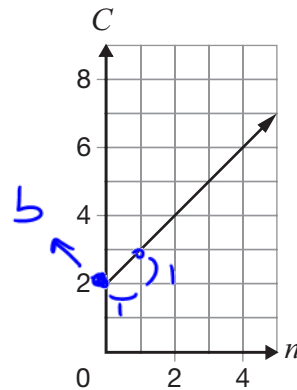

$m = 1 \quad b = 2$

$C = n + 2$

Which equation represents this relationship?

- a $C = n + 2$
- b $C = n + 1$
- c $C = 2n + 2$
- d $C = 2n + 1$

- 11 A local band pays \$5000 to record its first album and \$0.15 for each CD made. $C = 0.15n + 5000$
 The band pays \$7000 to record its second album and \$0.10 for each CD made. $C = 0.10n + 7000$

How will the graph of the relationship between the total cost and the number of CDs made for the second album differ from the graph for the first album?

The graph of the line for the second album will start

- a lower on the vertical axis and be steeper.
- b higher on the vertical axis and be steeper.
- c lower on the vertical axis and be less steep.
- d higher on the vertical axis and be less steep.



Go to the *Answer Booklet* and complete the seven open-response questions before continuing with question 19.

12 Open-Response

13 Open-Response

14 Open-Response

15 Open-Response

16 Open-Response

17 Open-Response

18 Open-Response

19 Which equation does **not** represent a linear relation?

a $y = 0$

b $x = 5$

c $x^2 + y = 9$

d $2x + y - 5 = 0$

20 What is the slope of the line represented by the equation below?

$$0 = 2x - 10y + 7$$

a 5

b $\frac{1}{5}$

c $-\frac{1}{5}$

d -5

$$\frac{10y}{10} = \frac{2x}{10} + \frac{7}{10}$$

$$y = \frac{1}{5}x + \frac{7}{10}$$

21 The end points of line segment AB are A(3, -12) and B(6, k).

What is the value of k if the slope of line segment AB is -2?

- a -18
- b -6
- c 6
- d 18

$$\frac{k - (-12)}{6 - 3} = -2$$

$$\frac{k + 12}{3} = \frac{-2}{1} \text{ cross mult.}$$

$$k + 12 = -6$$

$$k = -6 - 12$$

$$k = -18$$

22 Information about three different relationships between C, in dollars, and t, in hours, is shown below.

t (h)	C (\$)
0	10
2	14
4	18

$$A(0, 10) \quad B(2, 14)$$

$$m = \frac{14 - 10}{2 - 0} = \frac{4}{2} = 2$$

A
B

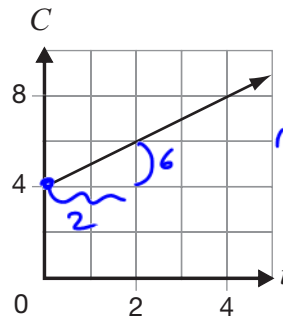

$$m = \frac{6}{2} = 3$$

$$C = 4 + 0.5t$$

$$m = 0.5$$

How many of the three relationships between C and t have a rate of change of \$4 per hour?

- (a) 0
- b 1
- c 2
- d 3

23 A line passes through the point (6, 4) and has a slope of $-\frac{1}{2}$.

Which of the following graphs represents this line?

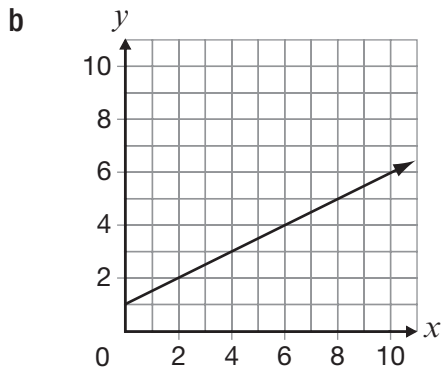
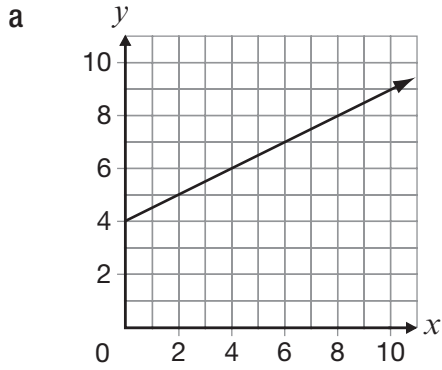

$$m = -\frac{1}{2} \quad (6, 4)$$

$$y = -0.5(x - 6) + 4$$

$$y = -0.5x + 3 + 4$$

$$y = -0.5x + 7$$

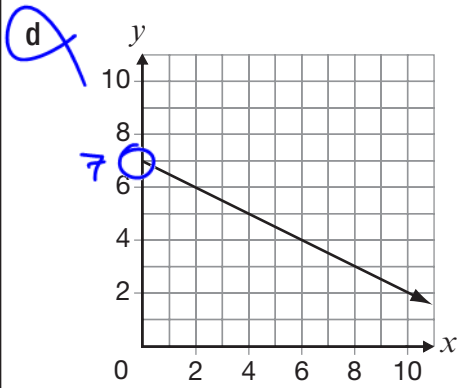
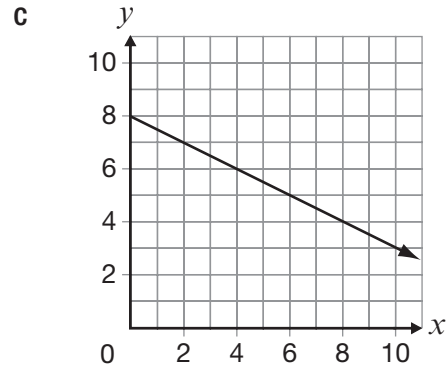

24 The maximum number of tickets that can be sold for a school play is 350.

The total profit earned, P , can be determined using the equation $P = 4.50n - 1080$, where n is the total number of tickets sold.

Which of the following statements is true?

- a The maximum profit is \$1080. **F**
- b The maximum profit is \$1575. **F**
- C** The total profit is \$0 when 240 tickets are sold.
- d The total profit is \$0 when 350 tickets are sold.

a&b $P = 4.5(350) - 1080$
 $P_{max} = 495$

c&d $P = 4.5n - 1080$
 $0 = 4.5n - 1080$
 $\frac{1080}{4.5} = \frac{4.5n}{4.5}$
 $n = 240$

25 Two gyms offer fitness classes. The graph below shows the total cost for the first gym.

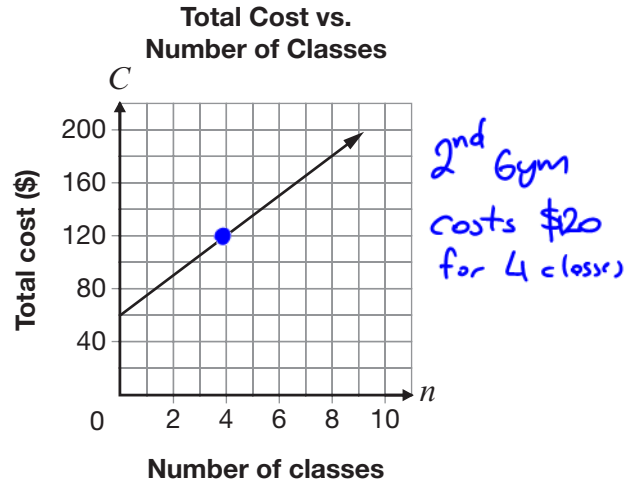

For 4 classes, both gyms have the same total cost.

Which of the following could represent the total cost for the second gym?

- F** a $C = 60 + 4n \Rightarrow 60 + 4 \cdot 4 = 76$
- F** b $C = 40 + 15n \Rightarrow 40 + 15(4) = 100$
- F** c The total cost is made up of a membership fee of \$60 and \$10 per class. $10n + 60 = 10(4) + 60 = 100$
- C** d The total cost is made up of a membership fee of \$40 and \$20 per class. $20(4) + 40 = 120$

26 The table below lists the widths of four rectangles, each with an area of 72 cm^2 .

	Width (cm)	Length
Rectangle 1	6	12
Rectangle 2	8	9
Rectangle 3	10	7.2
Rectangle 4	18	4

Which rectangle has the smallest perimeter?

- a Rectangle 1
- b Rectangle 2
- c Rectangle 3
- d Rectangle 4

27 Salt is sold in packages in the shape of a rectangular-based prism that is not a cube. A new package in the shape of a cube is designed to contain the same volume.

Which of the following is true about the new package?

- a It holds less salt.
- b It holds more salt.
- c It requires less material.
- d It requires more material.

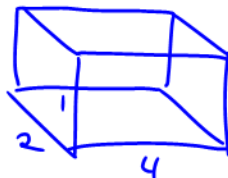

$$2(2 \cdot 4) + 2(2 \cdot 1) + 2(4 \cdot 1)$$

$$= 16 + 4 + 8$$

$$= 28$$



$$6 \times 2 = 24 \text{ cm}^2$$

28 According to the Pythagorean theorem, what is the length of the third side of the triangle, x ?

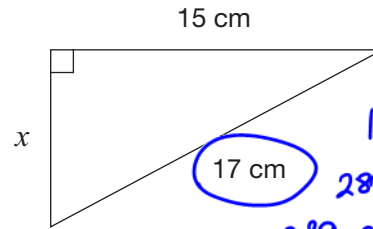

$$17^2 = x^2 + 15^2$$

$$289 = x^2 + 225$$

$$289 - 225 = x^2$$

$$\sqrt{64} = \sqrt{x^2}$$

$$8 = x$$

- a 2 cm
- b 4 cm
- c 6 cm
- d 8 cm

29 The figure pictured below is made up of a cone on top of a cylinder.

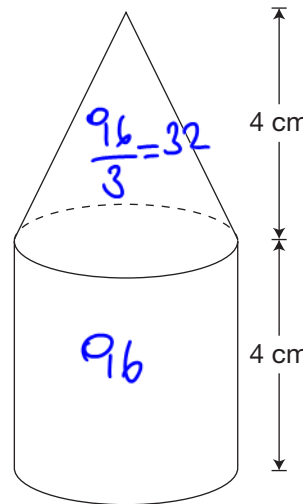

$$V_T = 96 + 32$$

$$= 128$$

The cylinder has a volume of 96 cm^3 .

What is the volume of the figure?

- a 120 cm^3
- b 128 cm^3
- c 144 cm^3
- d 192 cm^3

30 Consider the diagram below.

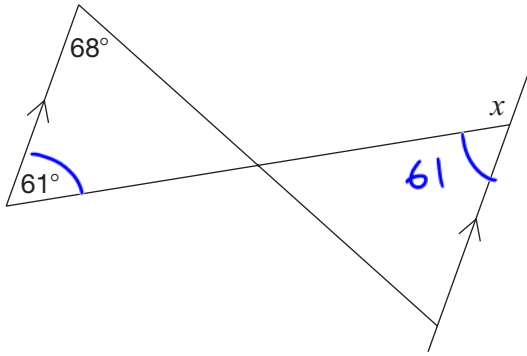

What is the value of x ?

- a 61°
- b 68°
- c 112°
- d 119°

$$\begin{aligned}
 x + 61 &= 180 \\
 x &= 180 - 61 \\
 x &= 119
 \end{aligned}$$

31 The following figure is a 15-sided regular polygon.

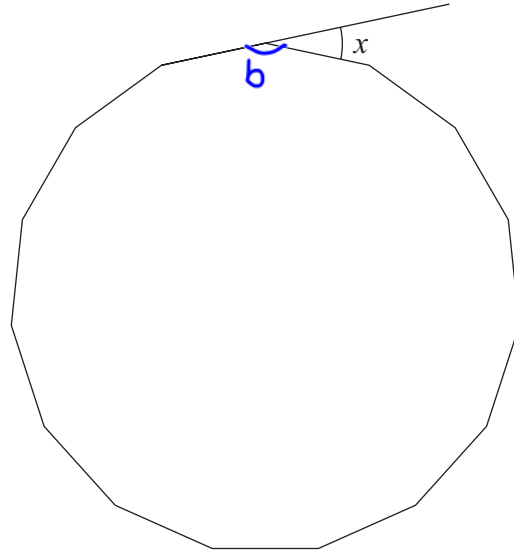

What is the value of x shown in the diagram?

$$\begin{aligned}
 \text{a } 24^\circ &= \frac{(15-2)180}{15} \\
 \text{b } 34^\circ & \\
 \text{c } 46^\circ & \\
 \text{d } 48^\circ &= 156^\circ \\
 x + 156 &= 180 \\
 x &= 24^\circ
 \end{aligned}$$